

Client: S.C. NIMFA-COM S.R.L.

**FACTURA**

Client: ADMINISTRARE ACTIVE  
SECTOR 3 SRL

Seria NIMFA nr. 28766  
Data (zi/luna/an): 10/09/2019  
Cota TVA: 19%

Reg. com.: 140/14752/2012  
CIF: RO31012790  
Adresa: Catea Vitau 242 Bucuresti  
Sect 3, Bucuresti  
Judet: Bucuresti



Nr. crt	Denumirea produselor sau a serviciilor	U.M.	Cant.	Preț unitar (fara TVA) -Lei-	Valoarea -Lei-	Valoarea TVA -Lei-
0	1	2	3	4	5(3x4)	6
1	Tabla LBC 4,0 x 1500 x 6000 material S235JR laminata la cald conform EN 10025-2 (00016391)					
2	UNP 100 x 50 x 6,0 material S235/275JR laminata la cald conform EN 10025-2 (00017293)					
3	Cornier 100 x 100 x 10 material S235JR laminat la cald conform EN 10025-2 (00014662)					
4	Cornier 50 x 50 x 5 material S235JR laminat la cald conform EN 10025-2 (00016695)					

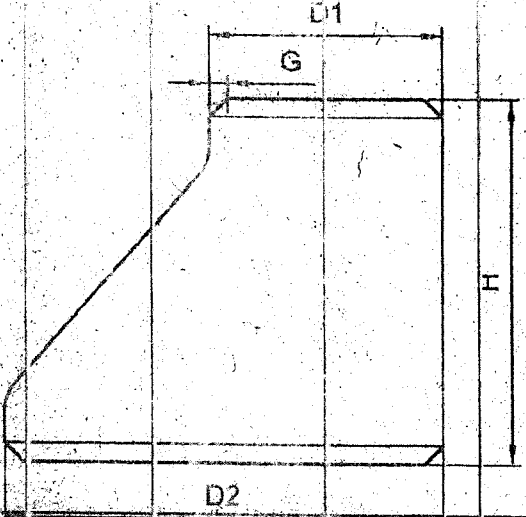
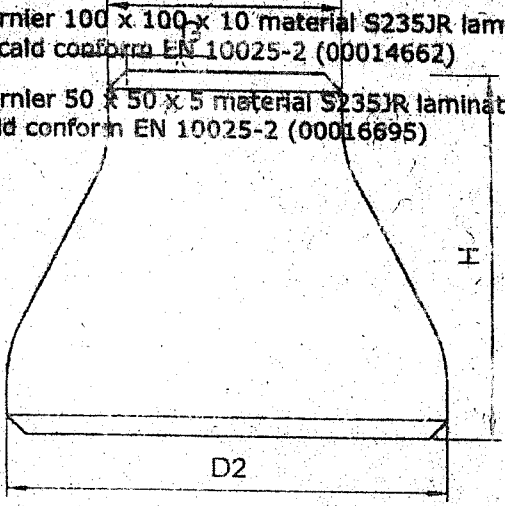

Receptia cantitativa si calitativa a marfii s-a efectuat in ziua livrarii, reclamatile ulterioare nefiind admise.  
 Conditia de livrare: INCOTERMS 2010 CPT  
 Locatia de livrare(adresa exacta sau in linii mari):

Factura se achita cu OP la 30 de zile.

Intocmit de:	Total	
CNP:		
Numele delegatului:	Total plata	18917.49
B/C.I.:		
Mijloc transport:	Semnatura de primire:	
Expediere la data de 10/09/2019 ora 14:34		
Semnaturile:		

Termen plata: 09/10/2019